

BRIGHTWELL

NEXUS

Laundry Dispensing System Product Datasheet



Key Features

- 3 - 8 pumps
- Suitable for 20 lb - 500 lb single machines
- Highly durable low-maintenance pumps
- Individual pump speed control
- Touchpad, Bluetooth or Wi-Fi configuration
- Multiple signaling modes - Relay, AFS, and Levels
- Up to 30 wash programs
- CE and UL Certified
- Two-year warranty



Easy Installation



Remote Management



Azure Data Security



Cloud Data Insights



Chemical Resistant Materials

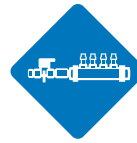

Comprehensive Accessories



Program Flexibility



Efficient Data Capture

Technical Specifications: Nexus Unit

Model Number	Voltage & Frequency	Power	Weight	Packaging Dimensions (approx. in) L x W x H
				* Pump modules supplied separately for 7 and 8 pump units
NM3-G01-U9 Nexus 3 Pump	110-230V 60Hz	120W	7.3 lb	19.29 x 11.42 x 8.27
NM4-G01-U9 Nexus 4 Pump	110-230V 60Hz	120W	7.9 lb	19.29 x 11.42 x 8.27
NM5-G01-U9 Nexus 5 Pump	110-230V 60Hz	150W	10.6 lb	32.28 x 11.42 x 8.27
NM6-G01-U9 Nexus 6 Pump	110-230V 60Hz	180W	13.0 lb	32.28 x 11.42 x 8.27
NM7-G01-U9 Nexus 7 Pump	110-230V 60Hz	210W	15.7 lb	32.28 x 11.42 x 8.27 + 12 x 10.83 x 6.3 (x1)*
NM8-G01-U9 Nexus 8 Pump	110-230V 60Hz	240W	18.1 lb	32.28 x 11.42 x 8.27 + 12 x 10.83 x 6.3 (x2)*

In the Box

Nexus pump unit (order dependent)

QuickStart Guide

Mounting kit

Quick Connect Fitting (order dependent)

Customer logo branding available

Max print area: W - 2.36" x H - 1.18"

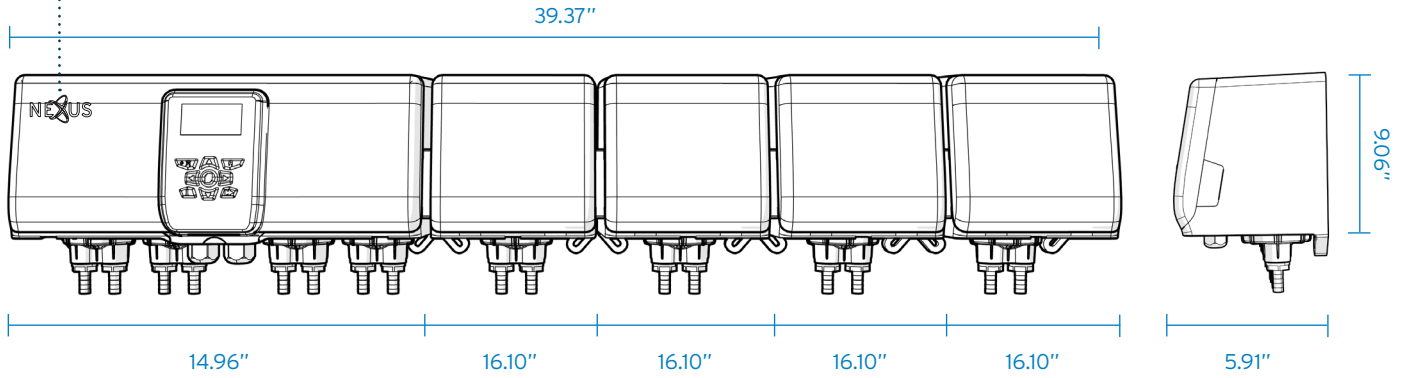

Available Accessories

Part Number	Description
XLM5-4D06-Q/M/U9	Modular Manifold 4-Way 1/4" Inlets, 3/8" Quick Connect Outlet
XLM5-4D10-10/M/U9	Modular Manifold 4-Way 3/8" Inlets, 3/8" Barb Connect Outlet
XLM5-6D06-Q/M/U9	Modular Manifold 6-Way 1/4" Inlets, 3/8" Quick Connect Outlet
XLM5-6D10-10/M/U9	Modular Manifold 6-Way 3/8" Inlets, 3/8" Barb Connect Outlet
NFS-G01	Formula Select



Technical Specifications: Nexus Membrane Pump

Flow Rate Per Minute	10 oz - 60 oz* * Using water
Max. Horizontal Tube Inlet	300'
Max. Horizontal Tube Outlet	650'
Recommended Prime Height	5'
Max Prime Height (Water)	8'
Max. Outlet Tube Height	65'
Max. Outlet Pressure	35 psi
Max. Viscosity	1500 cP

Wetted Materials

Pump Body	PVDF (Kynar)
Valve Washer	PVC (Vinyl)
Valve Umbrella	Extreme Viton * Other materials optional
Pump Membrane	PTFE (Teflon)

Approximate Pump Flow Rates

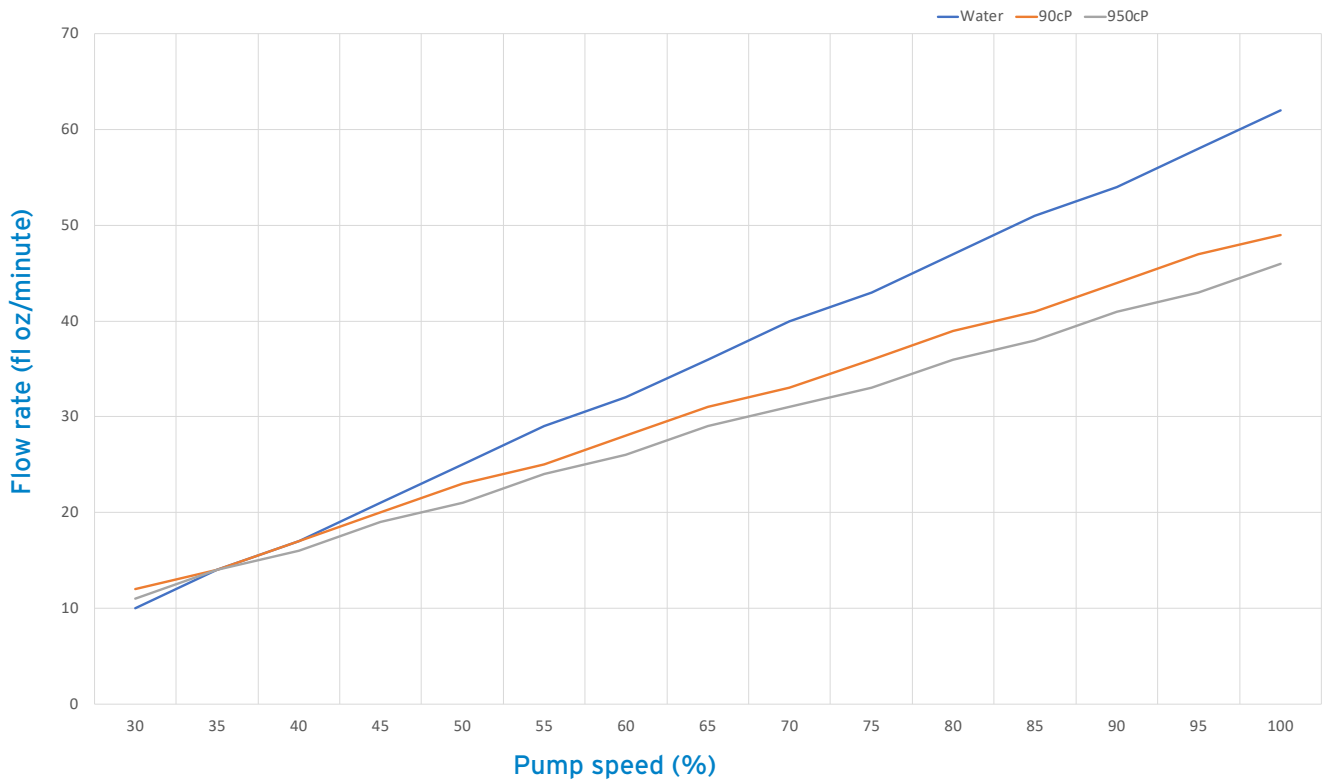

Chemical Compatibility

Bleach - 6-(Phthalimido)Peroxyhexanoic Acid (30%)

Conditioner/Softener - Esterquat (30%)

Detergent - Pentasodium Triphosphate (30%)

Detergent - Sodium Dodecyl Benzene Sulphonate (30%)

Emulsifier - Alcohol Ethoxylate 6.5MEO (30%)

Hydrogen Peroxide (50%)

Peracetic Acid (20%)

Phosphoric Acid (40%)

Sodium Hydroxide (40%)

Sodium Hypochlorite (30%)

D'limonene

Flow Rate with Different Viscosities

Pump Speed %	Water (fl oz/min)	90 cP (fl oz/min)	950 cP (fl oz/min)
100	62	49	46
95	58	47	43
90	54	44	41
85	51	41	38
80	47	39	36
75	43	36	33
70	40	33	31
65	36	31	29
60	32	28	26
55	29	25	24
50	25	23	21
45	21	20	19
40	17	17	16
35	14	14	14
30	10	12	11



brightwell-inc.com
 sales@brightwell-inc.com
 +1 913-956-4909