



EcoSprayer

Product Datasheet



Description

Our EcoSprayer system is a reliable and durable solution for cleaning and disinfecting small to medium surfaces. It is designed for ease of use with its practical handle and spray gun featuring a rotating connector. The EcoSprayer utilizes a venturi system and stainless-steel nozzle to provide optimal coverage and efficiency.

Key Features

- Integrated stainless steel nozzle exit offers a flat jet spray
- High chemical compatibility from all components
- Easily detach gun and attach wand for rinsing
- Standard with 40' hose. Additional lengths available.
- Optional wall bracket for easy storage

Technical Specifications

Operation	Easy activation with locking trigger and push-button release on spray gun
Installation	Requires mains water connection Minimum water pressure: 22 PSI Maximum water pressure: 116 PSI Max. suction height 5' 5"
Dilution	Dilution ratio is selected with supplied metering tips ranging from 15:1 to 333:1
Capacity	Standard - 34 oz container (84 oz option available)
Water Temperature	Up to 130°F
Material	Polypropylene housing, PVDF venturi body

In the Box

EcoSprayer Gun	40' hose
EcoSprayer Lid	Wall bracket (optional)
EcoSprayer Reservoir	Installation kit
EcoSprayer Rinsing Wand	Instruction Manual

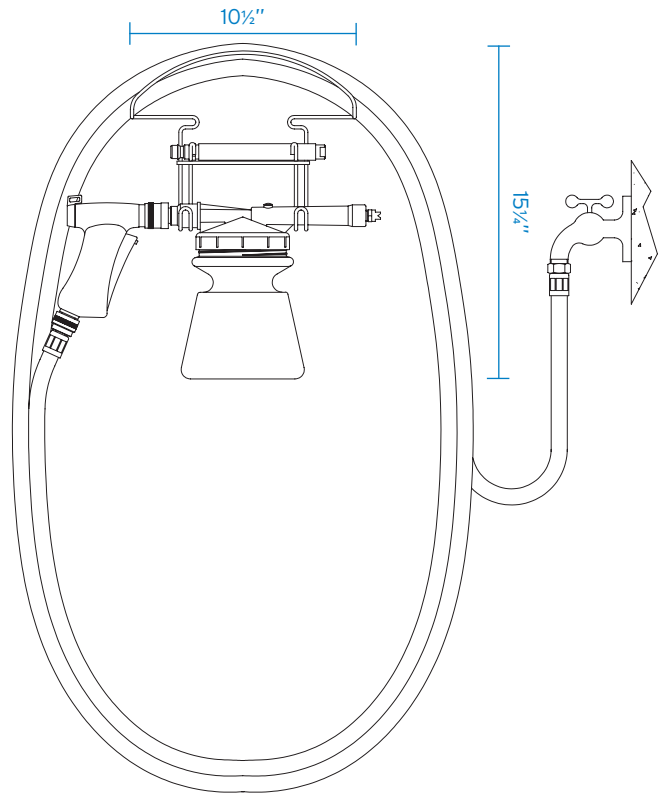
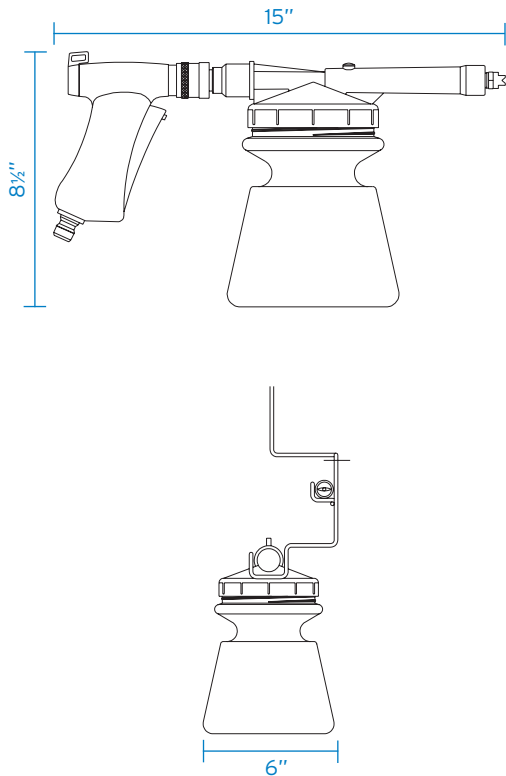

Dimensions

Width	15"
Height	8 1/2"
Depth	6"

Weight

Unit	3.3 lbs
------	---------

Part Numbers

DS10L	Hand held sprayer with rinse wand
DS10KIT	Hand held sprayer with rinse wand, hose and bracket

Available Accessories

Part Number	Description
XSB2003/U9	33' Hose
XSB2004/U9	50' Hose

Shipping Info

Shipping Method	Quantity of Units	Dimensions L x W x H (in)	Net packed weight (lbs)
Unit	1	14" x 14" x 10 1/2"	16.5 lbs

T (+1) 913-956-4909 **E** sales@brightwell-inc.com **W** brightwell-inc.com

Brightwell Dispensers Inc. 9858 Britton Street, Lenexa, KS, 66219

All information in this data sheet is correct at the time of printing and is subject to change without notice.