

# BRIGHTWELL



## MULTIPLEX

Brightwell Web Server User Guide

# CONTENTS

CONNECTING TO THE UNIT WEB SERVER	3
OVERVIEW	4
CHANNELS TAB SETTINGS AND OPTIONS	5
EDITING OR CREATING A NEW PRODUCT	6
EDITING OR ADDING A NEW CHANNEL	11
WASHERS	16
EDITING OR ADDING A NEW WASHER	17
FORMULAS	23
EDITING OR ADDING A NEW FORMULA	24
RUNNING A CALIBRATION WITH THE CONFIGURATION TOOL	27
RUNNING A CLEANING FLUSH	29
REAL TIME VIEW	30
ADVANCED SETTINGS	32
UPLOADING JSON FILES FOR THE FIRST TIME	33
MAKING CHANGES WITH A SINGLE JSON FILE	34

# CONNECTING TO THE UNIT WEB SERVER

## STEP 1

Each Multiplex unit enables direct connection through its web server. This connection is established via your computer's **Wifi network**. After powering on the unit, please allow 3 minutes for it to boot up and generate the server. To view available networks, simply click on the Wifi icon located in your toolbar.

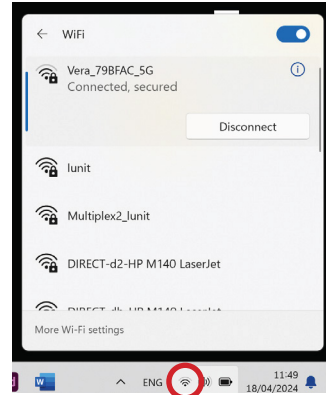

## STEP 2

Locate the network named according to Wifi, this appears as the make of the Multiplex and the unit serial, for example: "Wifi\_OPL-[123456]", click 'Connect' and you will be prompted to enter the network password for your unit. (This password would have been set up during the ordering process)

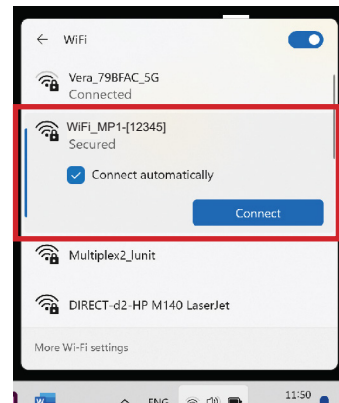

## STEP 3

Open your chosen web browser and enter the following address: [www.mp1pro.com](http://www.mp1pro.com)

\*Please note - It can take up to two minutes to connect

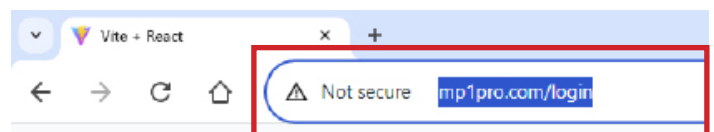

## STEP 4

Once the login page for the unit has displayed enter the information into the boxes provided. Once complete press the 'Enter' button to log into the unit. (This information was setup during the ordering process)

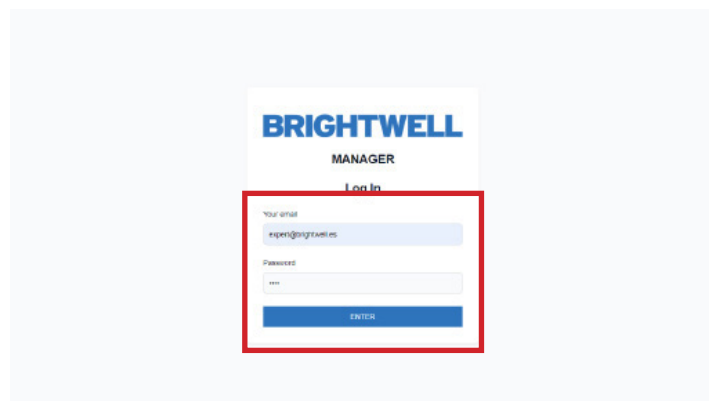

# OVERVIEW

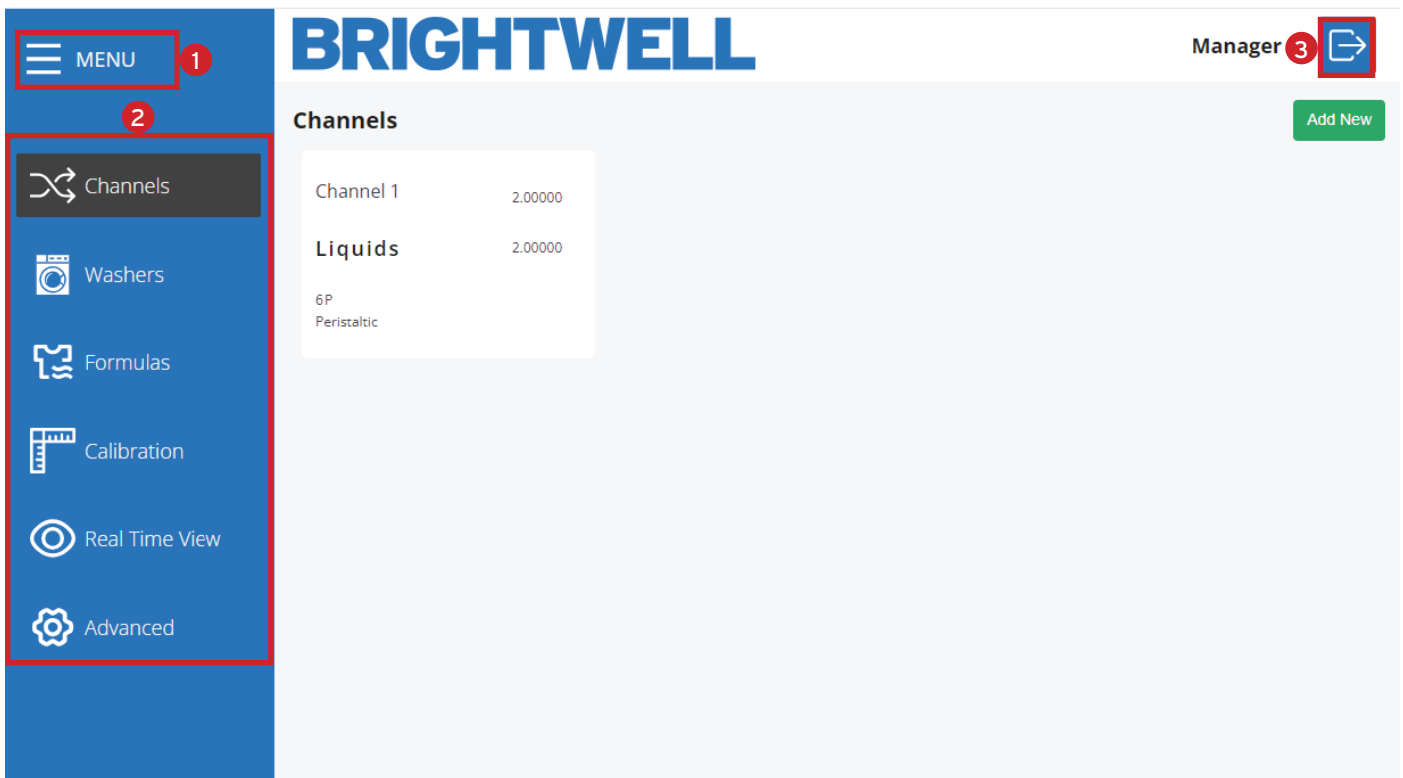

- 1** Number 1 highlights the expandable menu containing general settings for the configuration tool including;
  - Channels
  - Washers
  - Formulas
  - Calibration
  - Real time view
  - Advanced
  - Upload File
- 2** Number 2 is the side navigation bar displaying all menus allowing you to customise your Multiplex unit
- 3** Number 3 is how you disconnect from the unit.

# CHANNELS TAB SETTINGS AND OPTIONS

## STEP 1

The first menu is 'Channels' which allows you to edit an existing channel or create a completely new one. If you select a channel you will be presented with the current configuration settings.

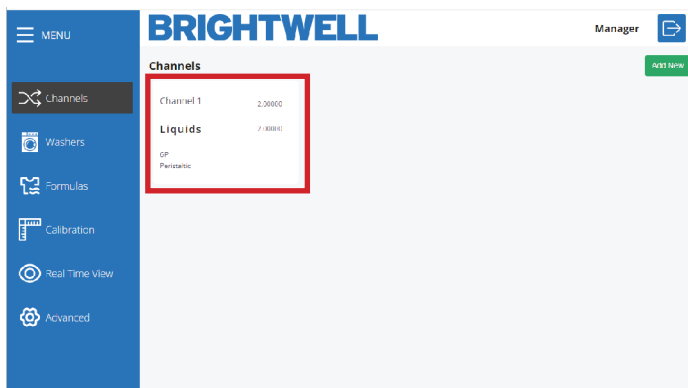

## STEP 2

These settings are divided into the two tabs [Parameters](#) and [Product](#) at the top.

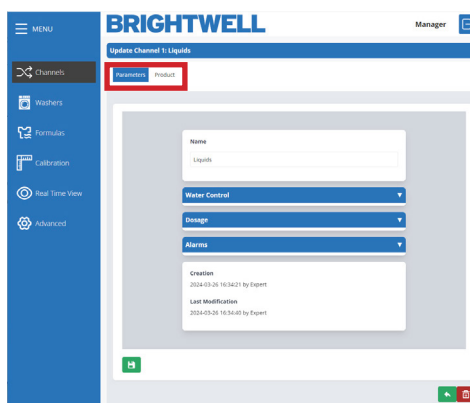

## STEP 3

Use the expandable sections in the **Parameters** section to navigate through the editable settings and configure as required. These are expanded in the later section - [Editing or Creating a New Channel \(P11\)](#)

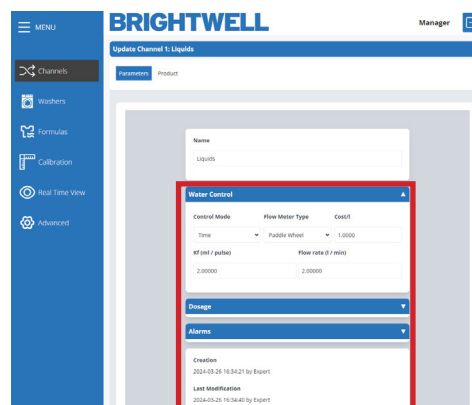

## STEP 4

If you open the **Product** tab to move across to this section. From here you can access the following menus:

- 1 Delete the chemical
- 2 Edit the chemical details
- 3 Add a new chemical
- 4 Exit the Product menu

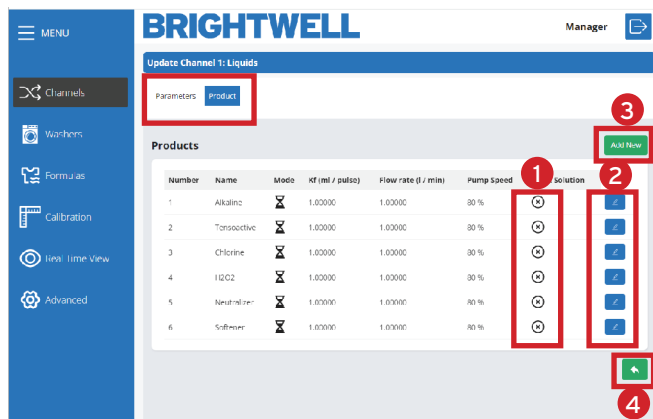

# EDITING OR CREATING A NEW PRODUCT

## STEP 1

To edit an existing product press the **Edit** icon on the right hand side of the list. Alternatively, to add a new product to your system press the **Add New** button.

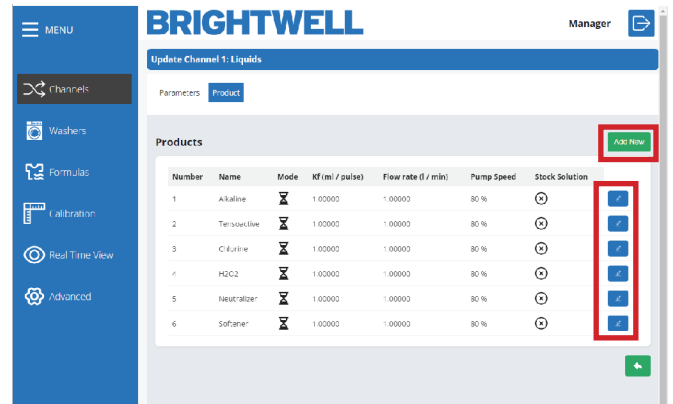

## STEP 2

Use the first box to set the **Custom Product Name** for the chemical so you can identify it clearly.

*It is advisable to be very precise with the name so no errors are made in selection.*

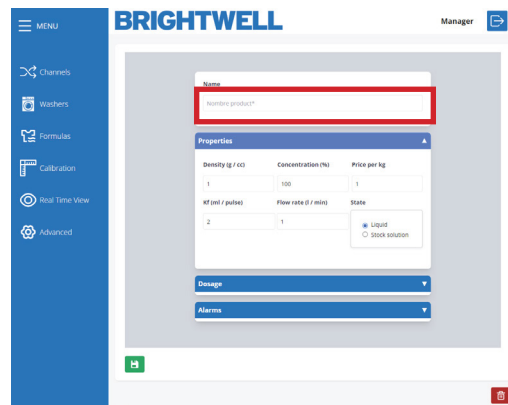

## STEP 3

The next box allows you to set the **Density** of the product. Please refer to the chemical manufacturers values for this.

We recommend that this value is precise and based on the chemical data sheet. As this directly effects the dosage of the chemical  
**X value density / 1kg of laundry**

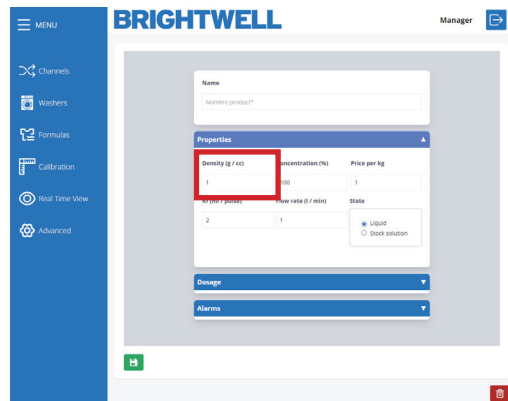

## STEP 4

Next set your Product Concentration percentage if this is diluted.

If you are using products in pre-dilution and want the 'grams of pure product' you should set this field percentage to the direct dilution of the product. For example:

**1000 litres you use 100kg of product your % = 1000/100 = 10%**

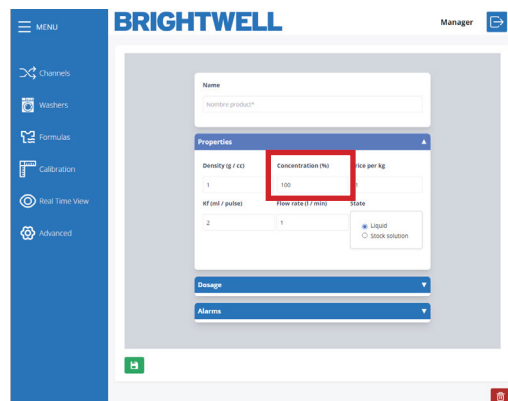

# EDITING OR CREATING A NEW PRODUCT

## STEP 5

Below you can set the Price per KG of the product for cost reporting.

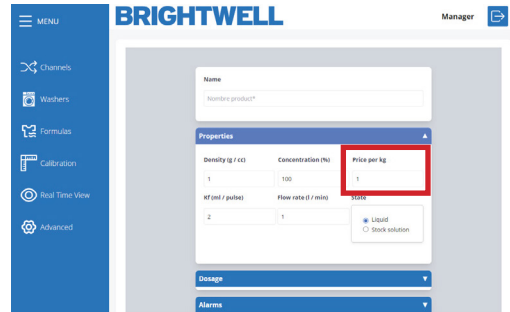

## STEP 6

Here you can adjust the Kf value as required.

(Please note - These values are generated automatically by running a calibration on the unit seen later in this guide: - Running a Calibration.)

\*We DO NOT advise setting the values manually

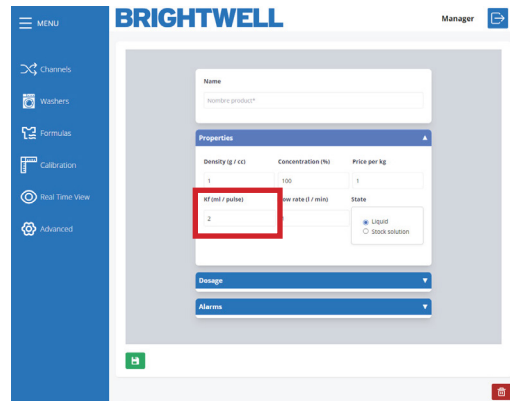

## STEP 7

You can now set up the Flow Rate value for the chemical here.

(Please note - These values are generated automatically by running a calibration on the unit seen later in this guide: - Running a Calibration.)

\*We DO NOT advise setting the values manually

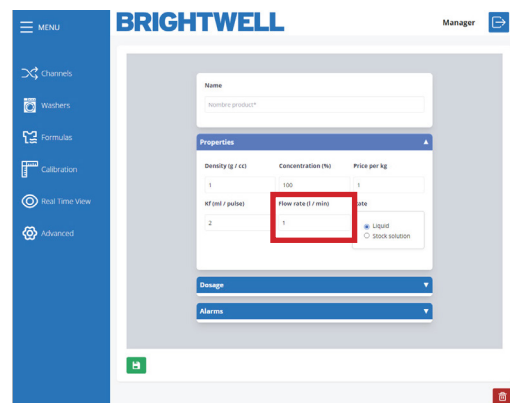

# EDITING OR CREATING A NEW PRODUCT

## STEP 8

You can now adjust the **State** of the product using the drop down. You can select between:

- Liquid
- Solid Solution

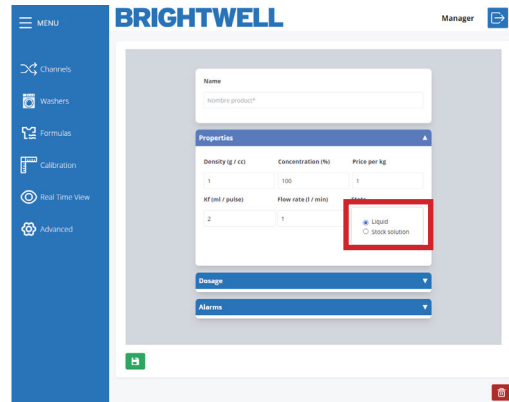

## STEP 9

Under the Dosage menu you can choose between:

- Modo de control
- Tiempo
- Caudalímetro

*Recomendamos utilizar un caudalímetro en todas las configuraciones para maximizar toda la funcionalidad de su Equipo Multiplex.*

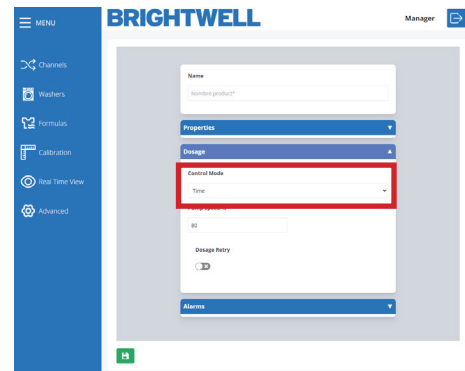

## STEP 10

Below you can now adjust the Pump Speed for this chemical.

*We recommend a speed of:*

- 80% - 100% for high volume delivery
- 30% - 80% for low volume delivery
- DO NOT use below 30% speed for delivery

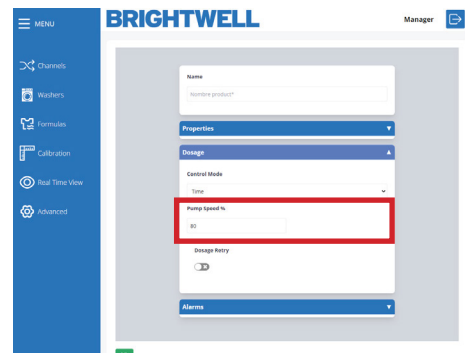

## STEP 11

The final setting in the dosage column allows you to enable or disable the **Dosage Retry**.

*This will enable the system to retry dosing the chemical if the correct number of pulses are not met in the expected delivery time.*

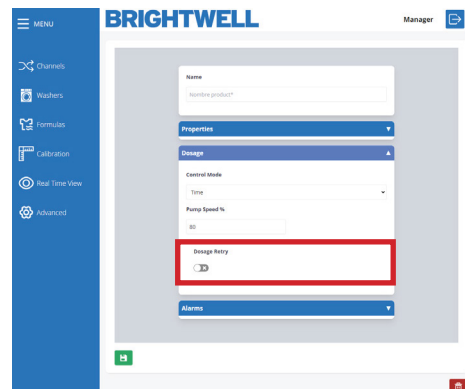

# EDITING OR CREATING A NEW PRODUCT

## STEP 12

At the bottom of the screen you can see the **Alarms settings**. The first box allows you to setup the **Pulse Detection Range**. You can select between:

- Low (30%)
- Medium (50%)
- High (70%)
- Maximum (100%)

This is the additional time that can be added for the flow meter to detect the correct volume of chemical. A more detailed explanation is found below:

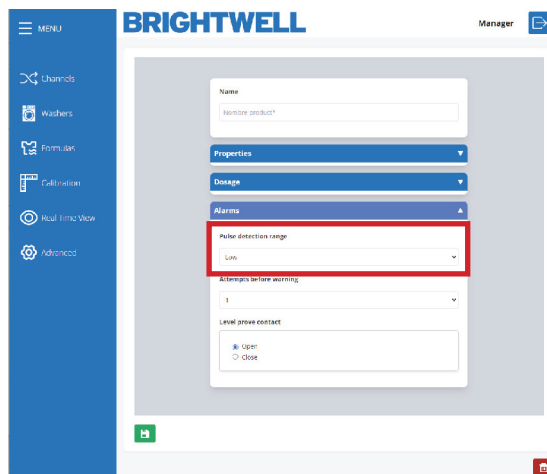

## PULSE DETECTION RANGE

When dosing chemical it may be required to increase the detection range to allow for fluctuations in flow for the product. This may be needed when there is potentially gassing products causing gas to expand in the pipe, or very viscous products that can become more difficult to pump if left sedentary.

Below is a graph explaining the functionality.

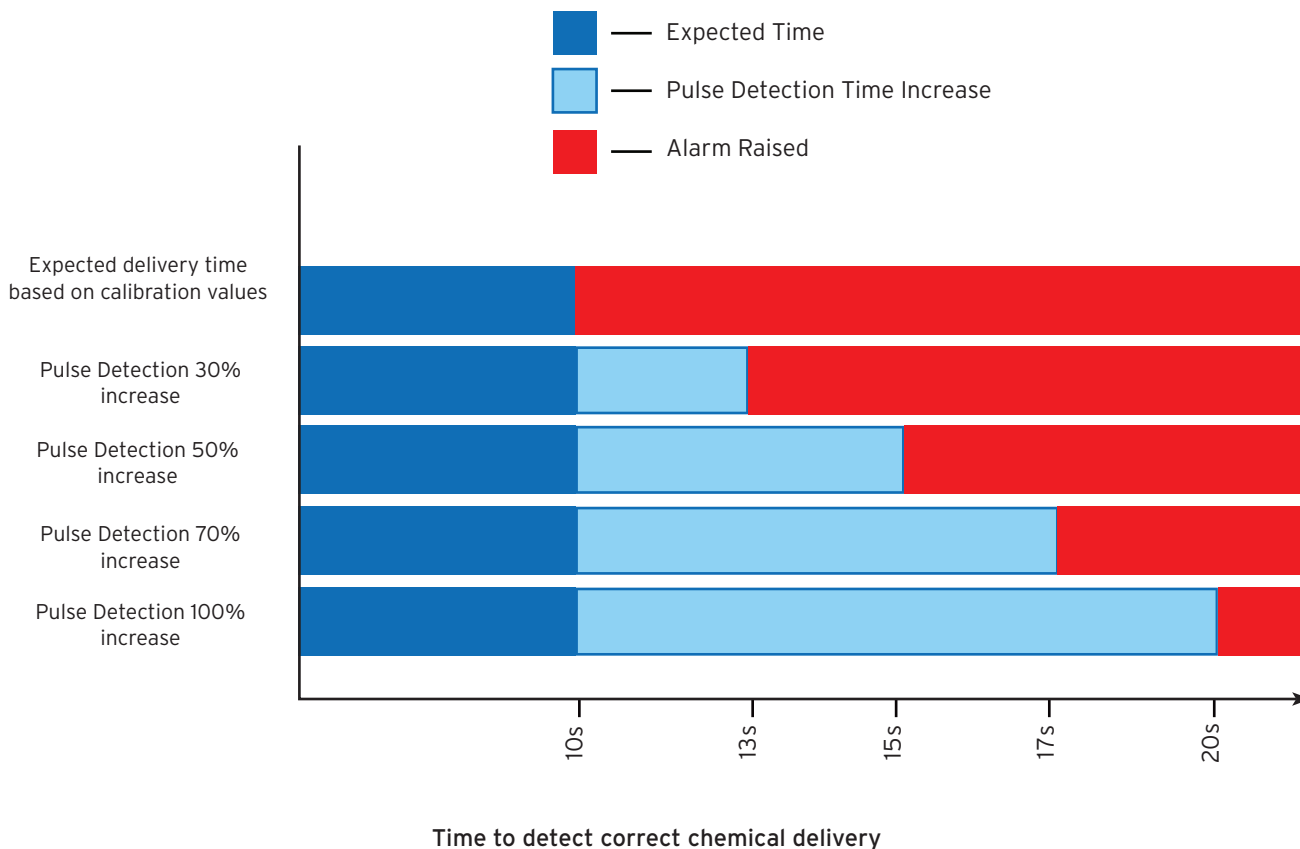

Please note - we advise setting this to as close to the expected delivery time as possible for accurate results and early warning of any potential hardware failures that may arise. Setting this to the maximum level by default will potentially hide maintenance issues that could be resolved before failure of the part.

# EDITING OR CREATING A NEW PRODUCT

## STEP 13

Below this you can set the number of retries before an alarm is raised.

*The feature is only available with a flow meter installed. This stops consecutive audio alarms from sounding on the unit to reduce noise pollution in the laundry.*

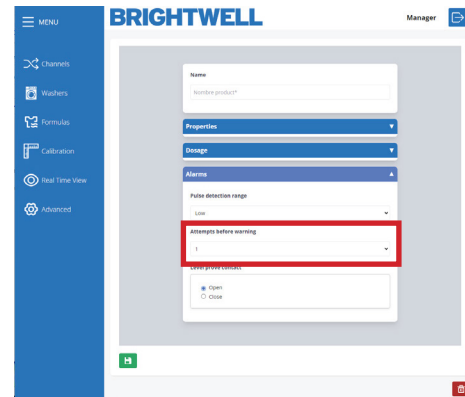

## STEP 14

Finally, you can adjust the Level Probe Contact to:

- Normally Open
- Normally Closed

*Please note - The standard Brightwell products are Normally Closed*

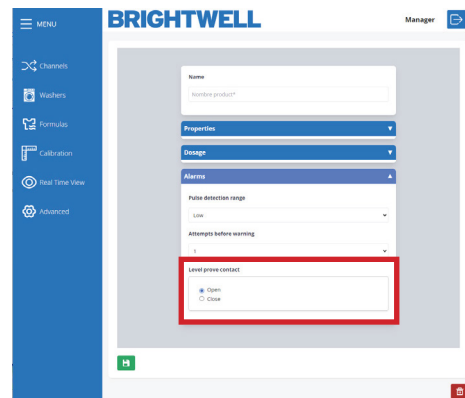

## STEP 15

Pressing the **Save** icon located in the bottom left will save the details and complete the setup. Alternatively, the **Delete** icon will remove the chemical.

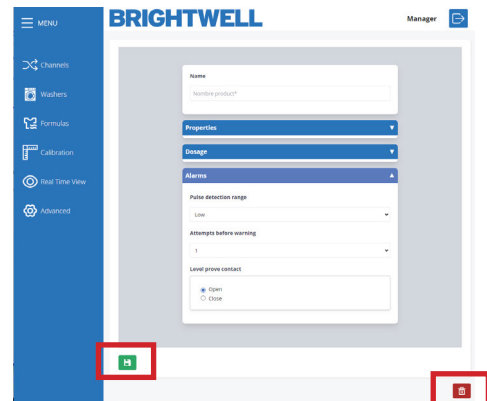

# EDITING OR ADDING A NEW CHANNEL

## STEP 1

To edit an existing channel press the **icon** in the channels list. Alternatively, to add an additional channel to your Multiplex setup press the **Add New** button in the top right of the screen.

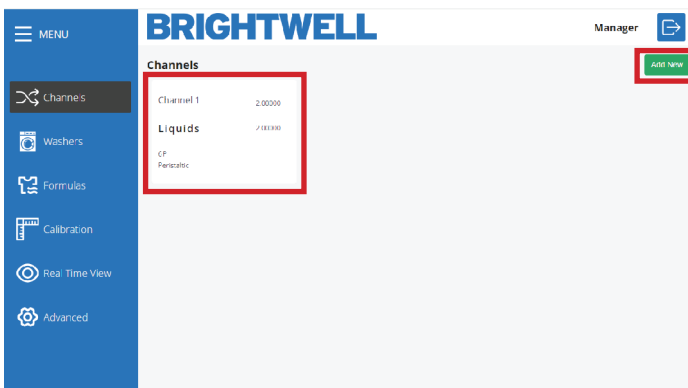

## STEP 2

Initially you can set the name for your new channel.

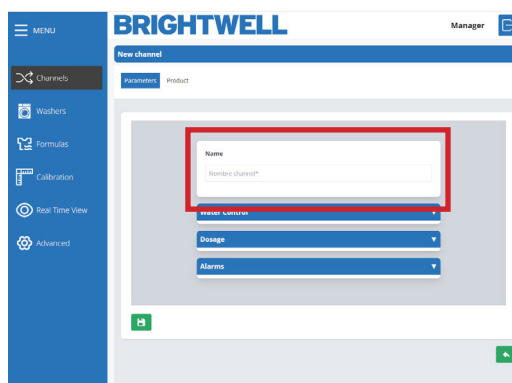

## STEP 3

The final setting in this menu is the **Control Mode**. Where you can select between Time or Flow meter.

\*We recommend using a flow meter for your Multiplex as it guarantees accurate chemical delivery to your machines. This option is to allow for temporary use of the unit while you await repairs.

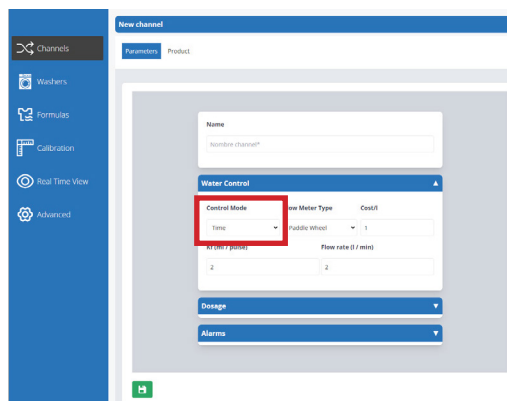

## STEP 4

Select the correct **Flow Meter Type** using the drop down:

- Paddles
- Oval-Gear
- Thermal

Please note: Do not change this unless you have replaced the flow meter provided from your supplier.

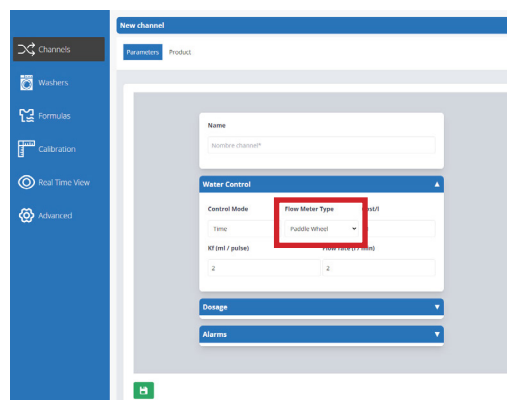

# EDITING OR ADDING A NEW CHANNEL

## STEP 5

Next is the **Cost** value for the water of this channel, this is used for cost reporting.

The screenshot shows the 'New channel' configuration window. On the left is a navigation menu with options: Channels, Washers, Formulas, Calibration, Real Time View, and Advanced. The main window has tabs for 'Parameters' and 'Product'. Under 'Parameters', there is a 'Name' field with a placeholder 'Nombrre channel?'. Below this is the 'Water Control' section, which includes a table with columns 'Control Mode', 'Flow Meter Type', and 'Cost'. The 'Cost' column has a value of '1' and is highlighted with a red box. Below the table are sections for 'Dosage' and 'Alarms'.

## STEP 6

Here you can adjust the **Kf** value as required.

(Please note - These values are generated automatically by running a calibration on the unit seen later in this guide: - Running a Calibration)

\*We **DO NOT** advise setting the values manually

This screenshot is similar to the previous one, but the 'Kf (ml / pulses)' field in the 'Water Control' table is highlighted with a red box. The 'Cost' field now contains a value of '1'.

## STEP 7

You can now set up the **Flow Rate** value for the chemical here.

(Please note - These values are generated automatically by running a calibration on the unit seen later in this guide: - Running a Calibration)

\*We **DO NOT** advise setting the values manually

This screenshot shows the 'New channel' configuration window with the 'Flow rate (l / min)' field in the 'Water Control' table highlighted with a red box. The 'Kf' value is now '2' and the 'Cost' value is '1'.

# EDITING OR ADDING A NEW CHANNEL

## STEP 8

If you need to adjust the [Pump Type](#) for the unit you can use the drop down menu to choose between:

- Peristaltic
- Motor
- Membrane
- Pneumatic
- Venturi

*The recommended configuration for the Multiplex is water or air flush with a membrane or pneumatic pump. (Based on each site)*

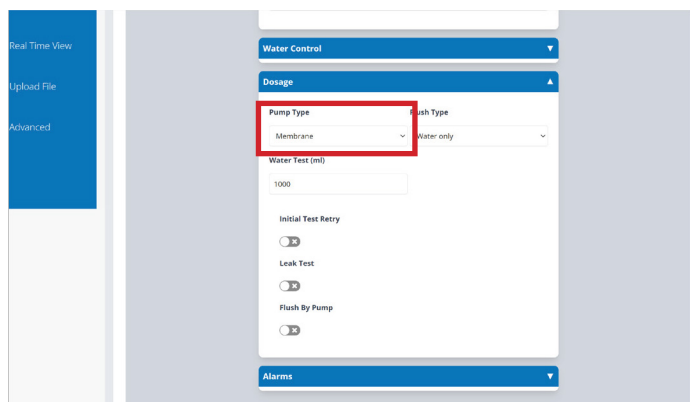

## STEP 9

If you need to adjust the [Flush Type](#) for the channel use this drop down to choose between;

- No Flush
- Only Water
- Air

*It is recommended to use water for set-ups where the distance between the distributor and unit is under 40 metres. Over 40 metres we advise using Air flush and a water test of over 1000ml to prevent product residue building up.*

*It is only recommended to use no flush when you have chemicals that become more viscous with water or the product is going directly to the washer.*

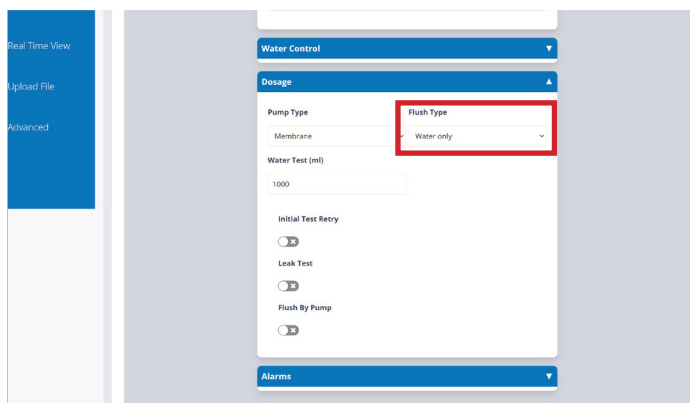

## STEP 10

Next you can adjust the Water Test volume for your channel. The minimum value for this is 700 ml to ensure a correct test and separation of chemicals.

*A water test is used to verify that the minimum indispensable conditions and that the product will reach its destination. A water test is recommended when products with high viscosity or high surface tension pass through the channel.*

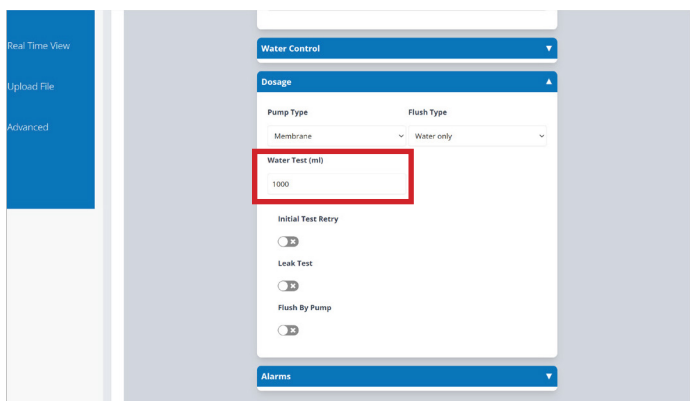

## STEP 11

Below this you can set the number of retries before an alarm is raised.

*The feature is only available with a flow meter installed. This stops consecutive audio alarms from sounding on the unit to reduce noise pollution in the laundry.*

*This is **ONLY** for the product dosage and water flush test. Not initial leak test.*

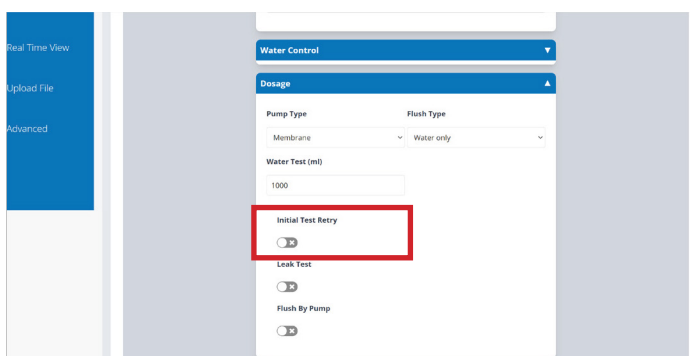

# EDITING OR ADDING A NEW CHANNEL

## STEP 12

Next enable or disable the [Leak Test](#) for the channel.

A leak test ensures that none of the valves on the unit are damaged by closing the valves and driving water to them, looking at the flow meter to see if any Pulses are detected. It is highly recommended that this option is enabled, however it may be needed to be deactivated for some examples:

- The pipe is soft and allows for expansion or compression
- There is a longer distance of pipe to the distributor
- The channel product is dosed directly to the distributor

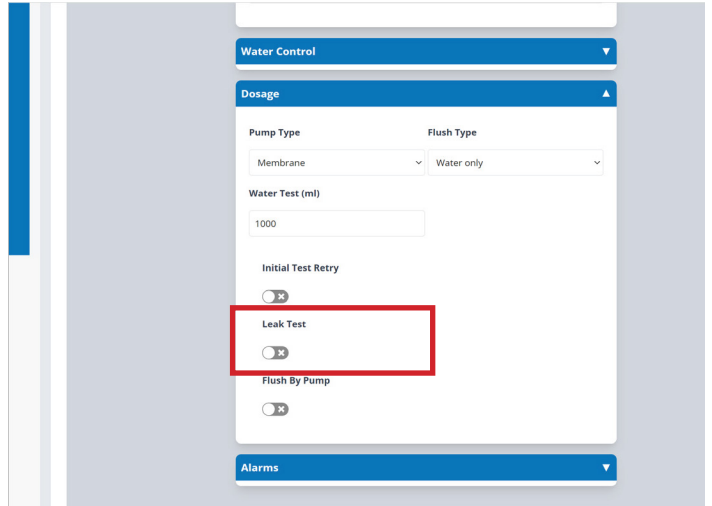

## STEP 13

Another [flush](#) setting can be adjusted next, selecting if you are flushing with only a pump or not.

\*This is not a recommended setup option and is only used when you do not have pressure regulated water for your setup. If this is the case, we advise the purchase of a booster tank to stabilise water pressure and ensure unit performance and reliability.

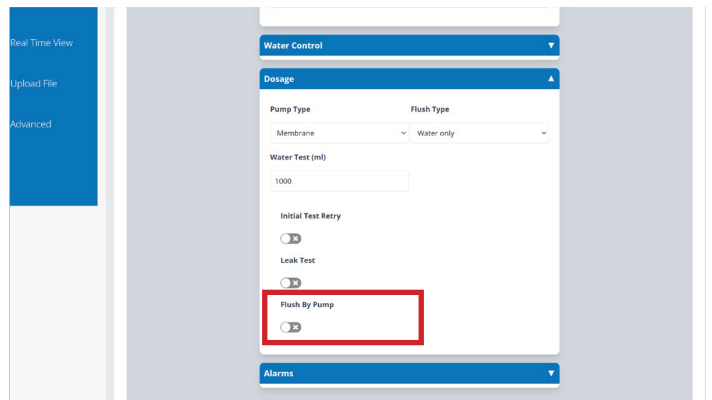

## STEP 14

At the bottom of the screen you can see the Alarms settings. The first box allows you to setup the Pulse Detection Range. You can select between:

- Low (30%)
- Medium (50%)
- High (70%)
- Maximum (100%)

This is the additional time that can be added for the flow meter to detect the correct volume of chemical. A more detailed explanation is found earlier here:

### Pulse Detection Range

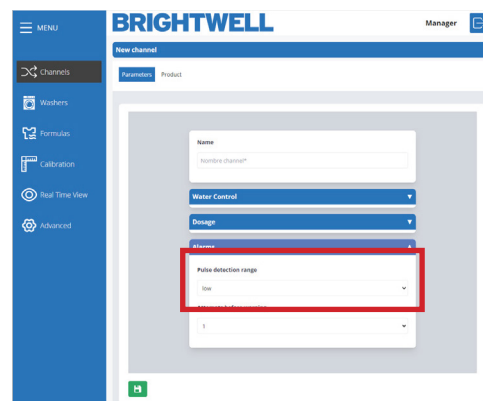

# EDITING OR ADDING A NEW CHANNEL

## STEP 15

Below this you can set the number of retries before an alarm is raised.

*The feature is only available with a flow meter installed. This stops consecutive audio alarms from sounding on the unit to reduce noise pollution in the laundry.*

*This is ONLY for the product dosage and water flush test. Not initial leak test*

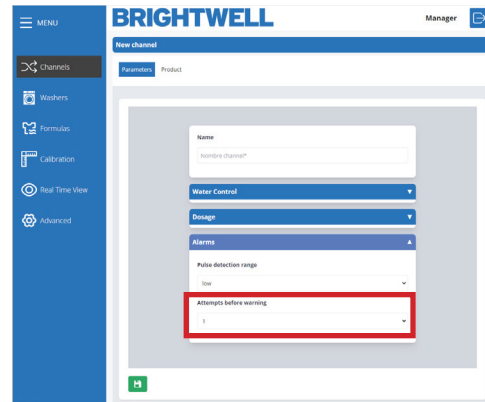

## STEP 16

To save your new channel and its settings press the **Save** icon located at the bottom left of the screen

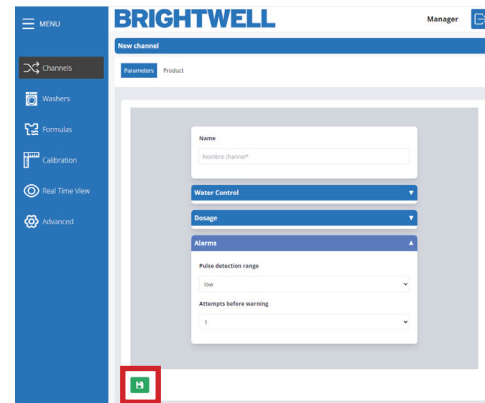

# WASHERS

The screenshot shows the BRIGHTWELL Manager interface. On the left is a blue sidebar menu with the following items: MENU, Channels, Washers (highlighted), Formulas, Calibration, Real Time View, and Advanced. The main content area is titled 'Washers' and features a red circle with the number '1' above it. Below this title are two cards representing washer configurations: 'Girbau' and 'Domus'. Each card shows a 50 kg capacity, a 'Time of the Signal: 1' indicator, and a 'No' status. A red box highlights the entire 'Washers' section. In the top right corner, there is a 'Manager' label and a blue arrow icon. Below these is a green 'Add New' button, which is highlighted with a green box and a red circle with the number '2'.

- 1** Number 1 are the current washers setup on the system giving you basic information on the machine details. You can click on any of these to open up the configuration and setup.
- 2** Number 2 is the side navigation bar displaying all menus allowing you to customise your Multiplex unit.

# EDITING OR ADDING A NEW WASHER

## STEP 1

To edit an existing washer click on the icon on the main Washers tab. Alternatively, to create a new press the Add New button located in the top right.

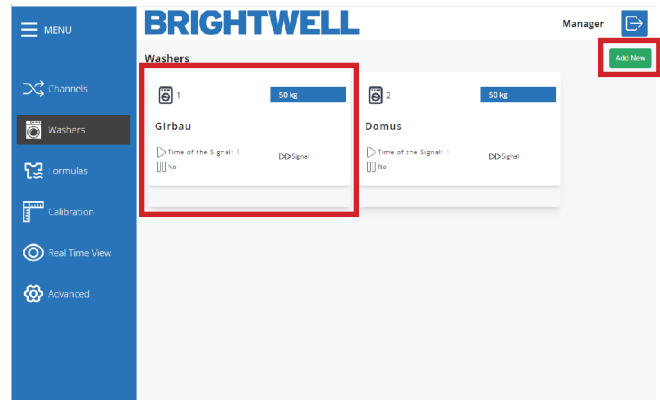

## STEP 2

The first section allows you to set the Custom Name for the washer.

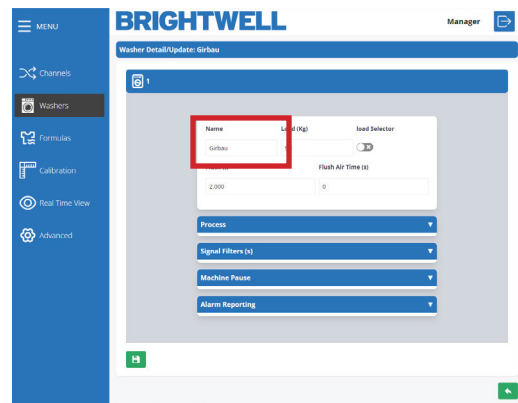

## STEP 3

Next, you can set the Total Load in Kg for the Washer.

*This field is essential in calculating the total volume to be dosed to the load.*

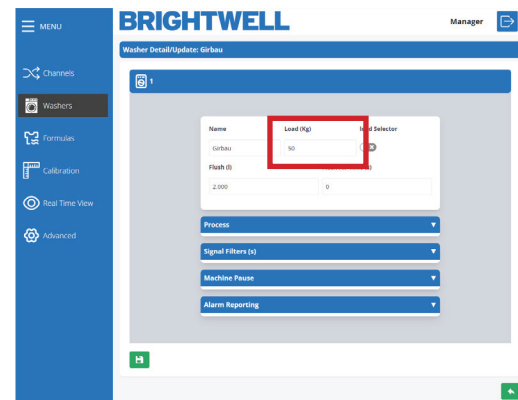

## STEP 4

You can now enable or disable the Load Selection for this washer.

*This setting requires a formula select, so please contact Brightwell to discuss this setting and equipment if required.*

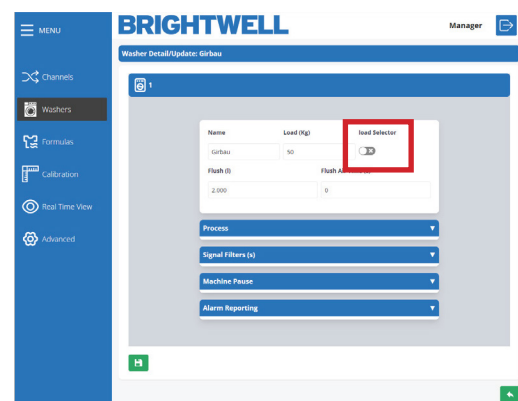

# EDITING OR ADDING A NEW WASHER

## STEP 5

The next box allows you to set the **Water Flush (I)** quantity required.  
Alternatively, if you are using air flush you can use the **Air Time (S)** box below this instead.

*This value needs to be precise for correct delivery of chemical. Please run a visual check of the water required to completely inject the chemical into the machine, as this varies based on distance from the distributor.*

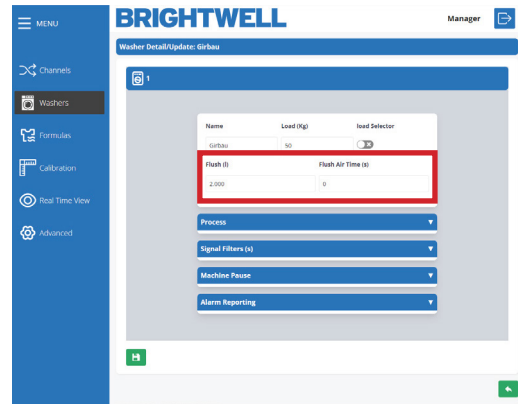

## STEP 6

In the Dosing Process column you can first set the Formula ID section. This can be:

- Selector
- Time of signal 8
- Time of signal 1+6
- Binary
- Free

Please refer to the next section for a more detailed explanation.

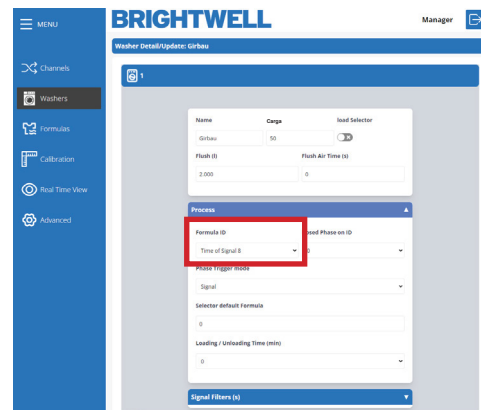

## SIGNAL TIME 8

Esto selecciona el programa basado en intervalos de 5 segundos de la Señal 8 que va alta. Esta configuración se aconseja para Equipos con un número inferior de fórmulas (1-20). Consulte la tabla siguiente para conocer los tiempos.

Formula	Signal 8 Time on	Formula	Signal 8 Time on	Formula	Signal 8 Time on	Formula	Signal 8 Time on
1	5 s	5	25 s	9	45 s	13	65 s
2	10 s	6	30 s	10	50 s	14	70 s
3	15 s	7	35 s	11	55 s	15	75 s
4	20 s	8	40 s	12	60 s	16...	80 s...

# EDITING OR ADDING A NEW WASHER

## SIGNAL TIME 1+6

This selects the program based on the duration of signals 1 and 6 going high simultaneously. This setting is advised for units that have a larger volume of formulas to select (20+) The below table explains the timing and selection details.

Formula	Signal 1 Time on	Signal 6 Time on	Formula	Signal 1 Time on	Signal 6 Time on	Formula	Signal 1 Time on	Signal 6 Time on	Formula	Signal 1 Time on	Signal 6 Time on
1	5 s	5 s	11	10 s	5 s	21	15 s	5 s	31	20 s	5 s
2	5 s	10 s	12	10 s	10 s	22	15 s	10 s	32	20 s	10 s
3	5 s	15 s	13	10 s	15 s	23	15 s	15 s	33	20 s	15 s
4	5 s	20 s	14	10 s	20 s	24	15 s	20 s	34	20 s	20 s
5	5 s	25 s	15	10 s	25 s	25	15 s	25 s	35	20 s	25 s
6	5 s	30 s	16	10 s	30 s	26	15 s	30 s	36	20 s	30 s
7	5 s	35 s	17	10 s	35 s	27	15 s	35 s	37	20 s	35 s
8	5 s	40 s	18	10 s	40 s	28	15 s	40 s	38	20 s	40 s
9	5 s	45 s	19	10 s	45 s	29	15 s	45 s	39	20 s	45 s
10	5 s	50 s	20	10 s	50 s	30	15 s	50 s	40	20 s	50 s

## BINARY

For this mode the unit will select a program based on the below signal combinations.

Formula	8	7	6	5	4	3	2	1
1								
2								
3								
4								
5								
6								
7								
8								
9								
10								
11								
12								
13								
14								
15								
16								
17								
18								
19								
20								
21								
22								
23								
24								
25								
26								
27								
28								
29								
30								
31								
32								
33								
34								
35								
36								
37								
38								
39								
40								
41								
42								
43								
44								
45								
46								
47								
48								

## FREE MODE

Free mode allows the users to build a custom list of formula selection based on incoming signals. These are **ONLY** defined via the web portal or web server, they cannot be defined on the On Screen setup.

# EDITING OR ADDING A NEW WASHER

## STEP 7

After this you can select the **Dosed Phase ID** number using the drop down here.

*This allows you to customise what state the machine will enter on receiving the first signal.  
If you set this to Phase 0, the unit will not begin dosing until a signal is received from the washer.  
If you set this to Phase 1 the unit will immediately begin to dose after the auto formula select signal is confirmed.*

The screenshot shows the 'Washer Detail/Update: Girebu' configuration page. The 'Process' section has 'Dosed Phase on ID' set to '0'. A red box highlights this dropdown menu.

## STEP 8

You can now choose between how the phase of dosification is activated, **Signal** or **Sequential**.

*Signal mode defines that the machine itself will send a signal to identify what phase it is entering.*

*Sequential mode sets it so that it will move sequentially through the phases one by one in a logical order.*

The screenshot shows the 'Washer Detail/Update: Girebu' configuration page. The 'Phase Trigger mode' dropdown menu is set to 'Signal' and is highlighted with a red box.

## STEP 9

If you have Selector chosen you will also have the option to set the **Selector Default Formula**. Which will default back to after a successful cycle.

The screenshot shows the 'Washer Detail/Update: Girebu' configuration page. The 'Selector default Formula' dropdown menu is set to '0' and is highlighted with a red box.

## STEP 10

Finally you can adjust the time required to load or unload the machine.

The screenshot shows the 'Washer Detail/Update: Girebu' configuration page. The 'Loading / Unloading Time (min)' dropdown menu is set to '0' and is highlighted with a red box.

# EDITING OR ADDING A NEW WASHER

## STEP 11

The final box in the **Signal Filters** column allows you to adjust the **Lock time** for the equipment to allow new signals, once the **RESET** has been completed.

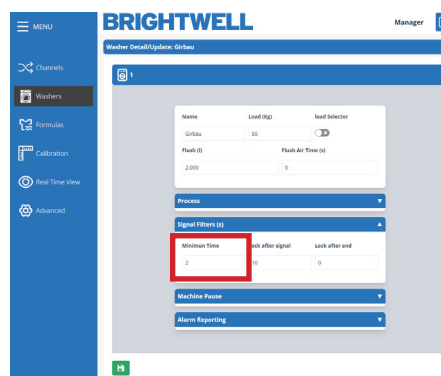

## STEP 12

You can then adjust the time that the device would block reception of signals, after having received a valid signal.

With this option, we prevent possible “bounces” of a signal from being mistaken for input signals

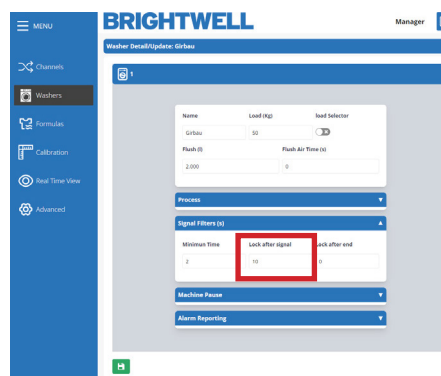

## STEP 13

In the **Signal Filters** column the first box allows you to adjust the **Minimum Time** for an accepted signal. This stops ghost signals from triggering the machine.

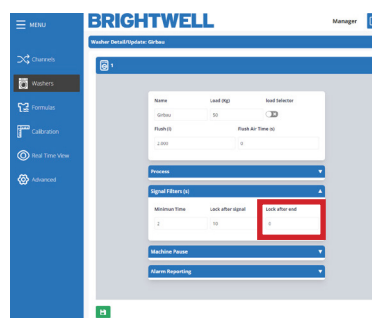

## STEP 14

The last column is the **W.E Pause (Washer Extractor Pause)** section.

The first box allows you to adjust the Activation between:

- No (Deactivated)
- While in queue
- While in queue and dosage

*The washer pause functionality allows for 'queuing' of machines when they request chemical delivery while the unit is busy.*

*When a machine is 'waiting' its timer is paused so that the wash can complete a full cycle correctly. The above options allow you to adjust when the 'pause timer' begins again.*

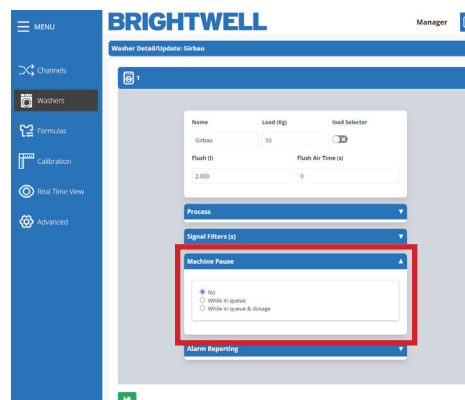

# EDITING OR ADDING A NEW WASHER

## STEP 15

The final section allows you to toggle what alarms are enabled on your washe:

- Missing Phases
- Internal Error
- Unfinished Process
- Level / Temp. Time-out
- Communication Errors
- Data Out Of Range

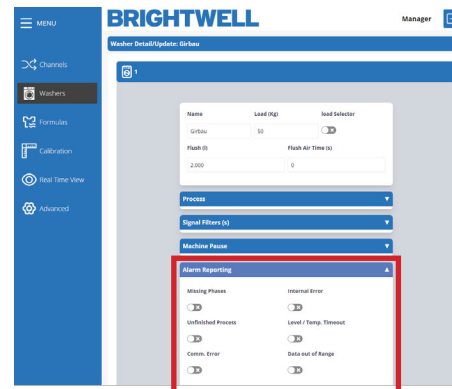

# FORMULAS

**BRIGHTWELL** Manager

**Formulas**

Number	Name	Phases	End Phase	Est. Time	Bleach
1	Bedsheets	1 2 3 4 5 6 7 8	4	45.00	Yes (with chlorine)
2	newFormula	1 2 3 4 5 6 7 8	4	60.00	Non-Specified

- 1 Number 1 is the **Add New** button to create a new formula
- 2 Number 2 displays the phases that have configuration data setup within the formula.
- 3 Number 3 is the **Edit** button, allowing you to edit the configuration of an existing formula.
- 4 Number 4 is the **Delete** button, allowing you to remove a formula.

# EDITING OR ADDING A NEW FORMULA

## STEP 1

To edit an existing formula on your system press the **Edit** button located on the right hand side. Alternatively, press the **Add New** icon in the top right to create a new formula.

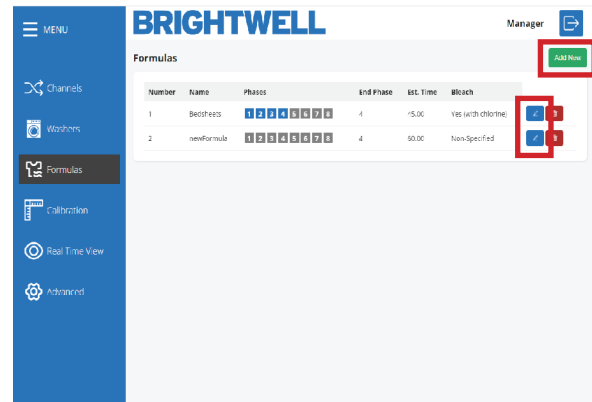

## STEP 2

The first two boxes allow you to edit the **Name** of the formula and the assigned **Program Number**.

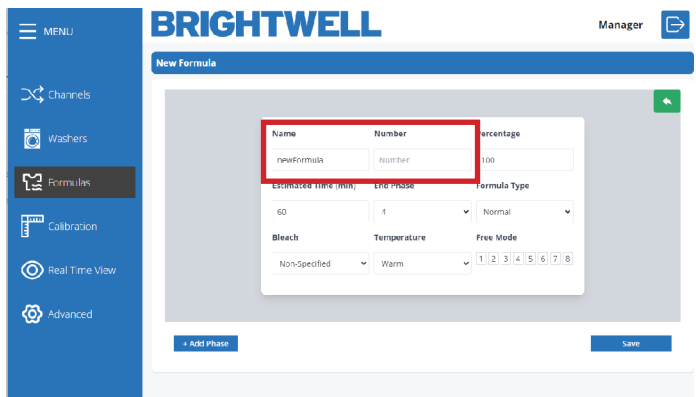

## STEP 3

Next you can adjust the **Percentage** value for this formula.

*This can be adjusted to reduce the percentage of product delivered for this formula. It can be used if dosing to a different sized machine etc.*

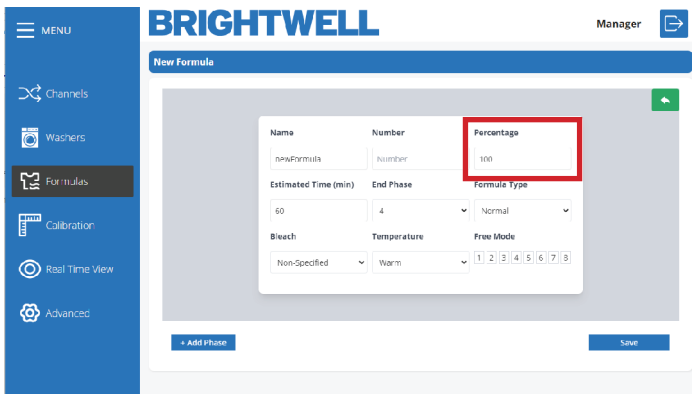

## STEP 4

After this you can adjust the **Estimated Time (min)** value for this formula.

*This is a rough time that the formula will take to complete.*

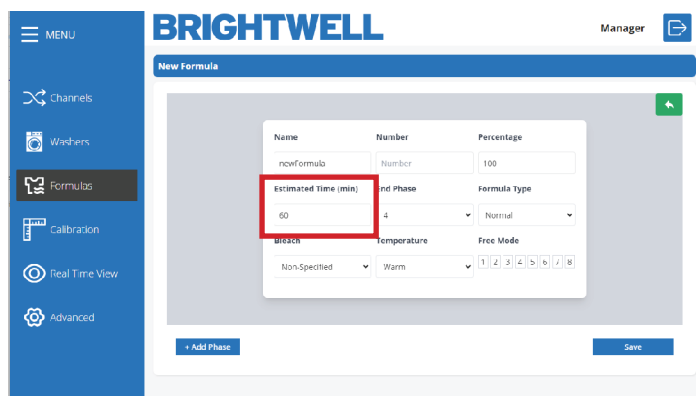

# EDITING OR ADDING A NEW FORMULA

## STEP 5

Using the drop down located here you are able to set the **End Phase** for this formula.

*The End Phase denotes what the final phase the washing machine needs to enter to trigger a complete cycle for this Formula.*

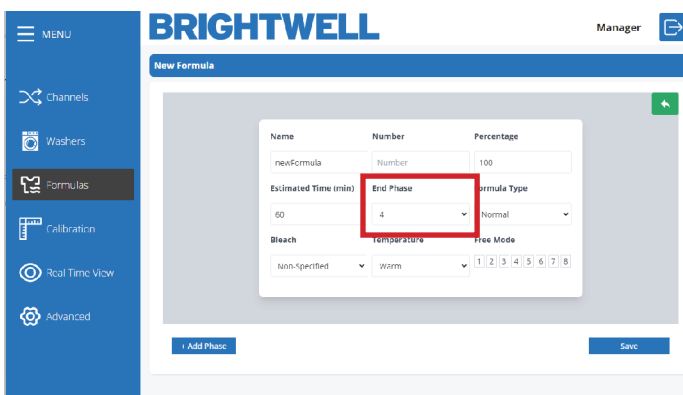

## STEP 6

You can now select the Formula Type you are creating:

- Delicate
- Normal
- Heavy Soil
- Re-Process
- Desize
- Rinse/Spinning
- Recovery
- Other

*This data is informative. It will be useful to obtain more complete statistics.*

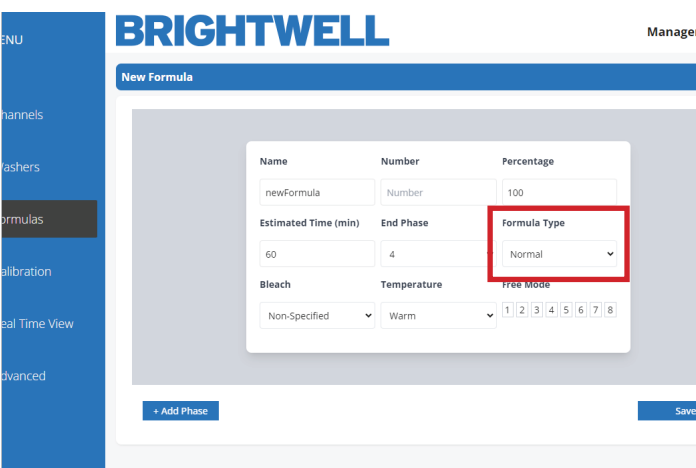

## STEP 7

If you have bleach for this formula, you can use the drop down here to select:

- Non Specified
- No bleach
- Yes (No chlorine)
- Yes (With chlorine)

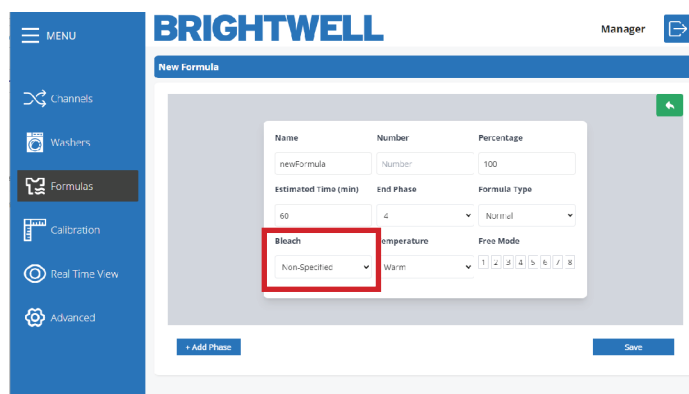

## STEP 8

You can now set the desired temperature for the formula:

- Cold
- Warm
- Hot
- High Temperature

*This data is informative. It will be useful to obtain more complete statistics.*

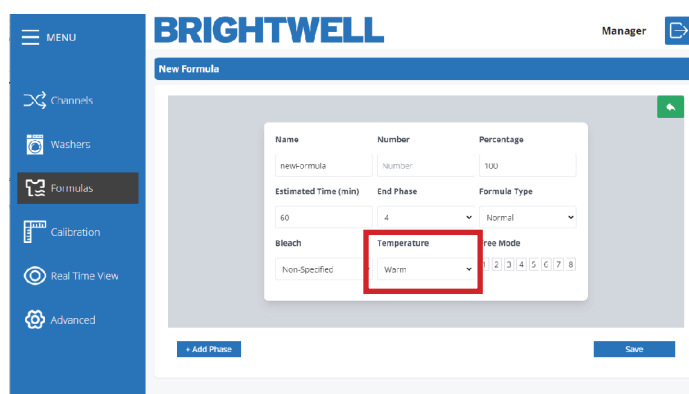



# RUNNING A CALIBRATION WITH THE CONFIGURATION TOOL

## STEP 1

To run a calibration on your Multiplex unit press the **Calibration** icon in the side menu, located here.

Please note - You can **ONLY** run a calibration via the web server.

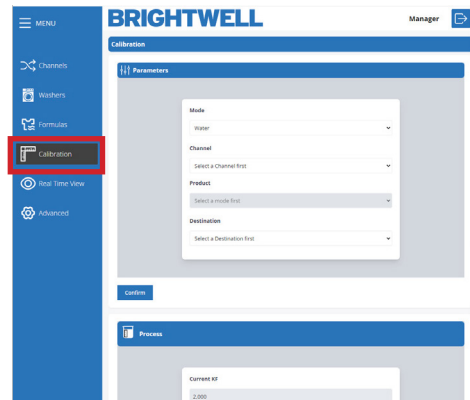

## STEP 2

Before you run a calibration on your unit you will need to confirm the details on that channel. Initially you need to select the mode. This can be **Water** or **Product**.

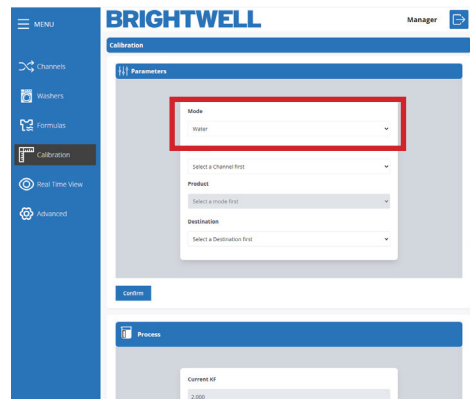

## STEP 3

Now you need to select the channel you would like to calibrate to. If you have a measuring vase attached use that. If not, you can either use an empty output or remove the pipe of the current product output and catch using a measuring device.

Please follow all chemical safety if removing piping.

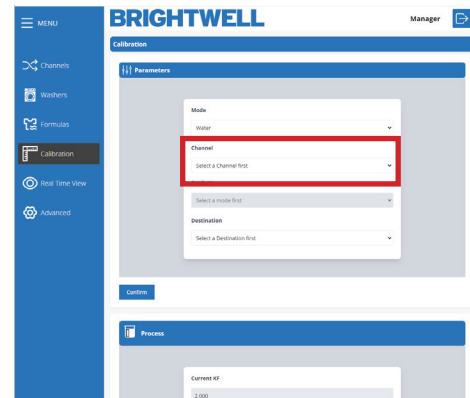

## STEP 4

If you have selected Product, you can select that using the drop down.

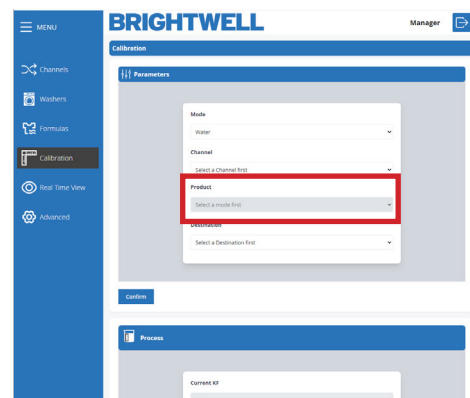

# RUNNING A CALIBRATION WITH THE CONFIGURATION TOOL

## STEP 5

Once you have confirmed the settings press the **Confirm** button to begin the calibration. Please confirm you have a measuring vase or suitable vessel ready to capture the outflow for calibration.

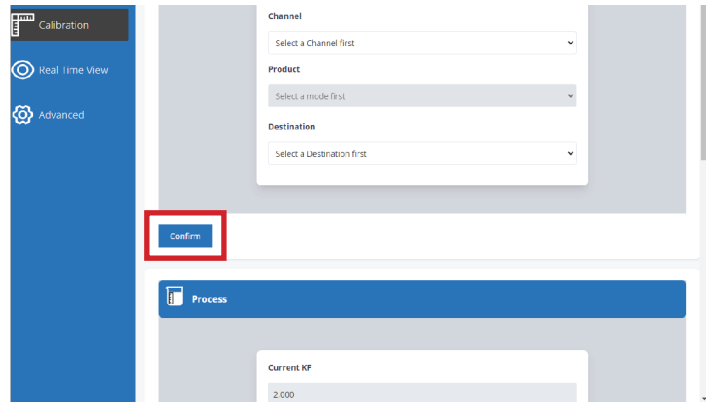

## STEP 6

Now that the unit is ready for calibration go to your unit and **press and hold** the [Calibration](#) button on the unit and it will begin to [flush](#).

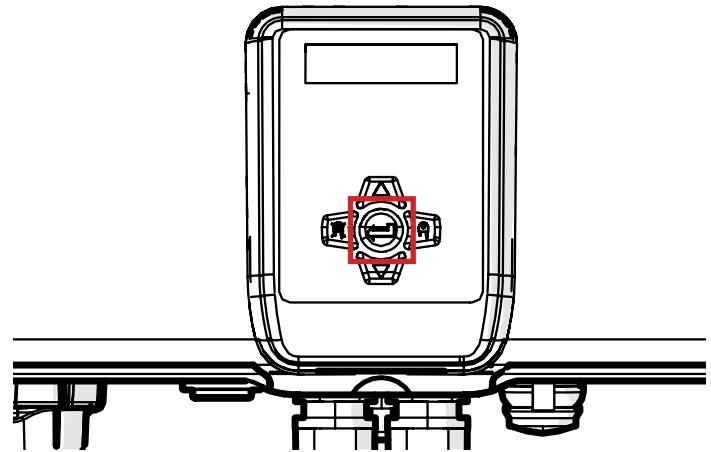

## STEP 7

Once the calibration has run confirm the volume of liquid dispensed and enter the values in the **Obtained Volume** tab. Press the **Confirm** button to save these settings.

The unit will now automatically generate the new **Flow rate** and **Kf** for the unit. Setting these values in the relevant sections

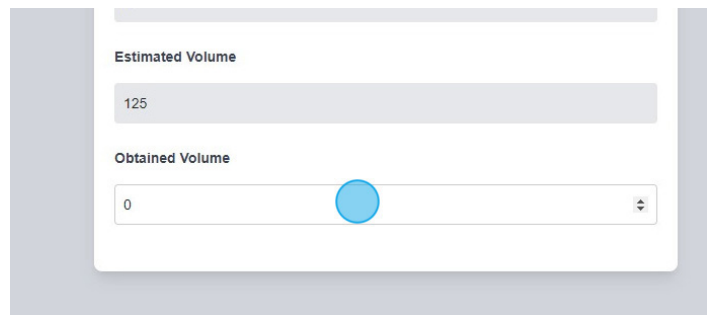

## STEP 8

Once calibration is complete, confirm the volume of liquid dispensed and enter the values in the Volume Obtained tab. Press the **Confirm** button to save these settings.

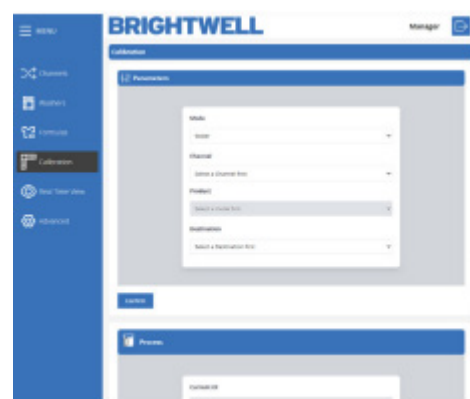

# RUNNING A CLEANING FLUSH

## STEP 1

After completing a calibration with product, **YOU MUST** run a cleaning cycle to clear all chemical from the channel. This will automatically show once you have entered the **Obtained Value** into the box. Press the button to begin

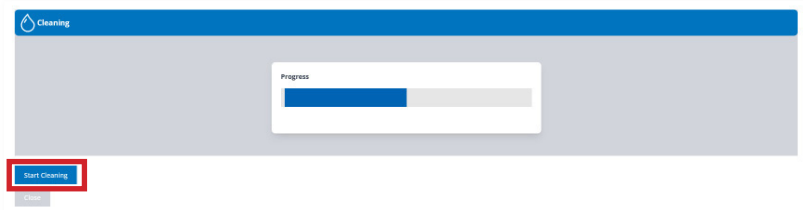

## STEP 2

Once a cleaning cycle has completed the progress bar will turn green.

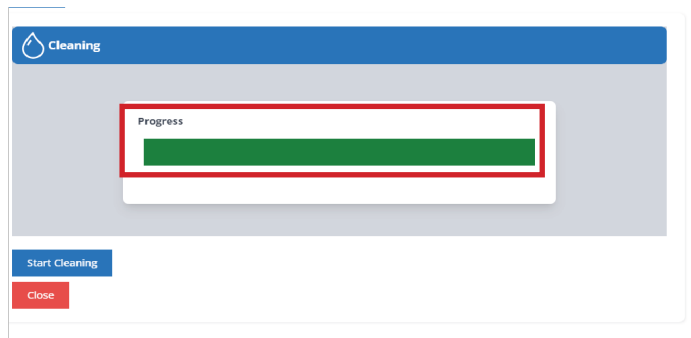

## STEP 3

Please note - While you are running a cleaning cycle, you are unable to leave the screen and all navigation options will be disabled.

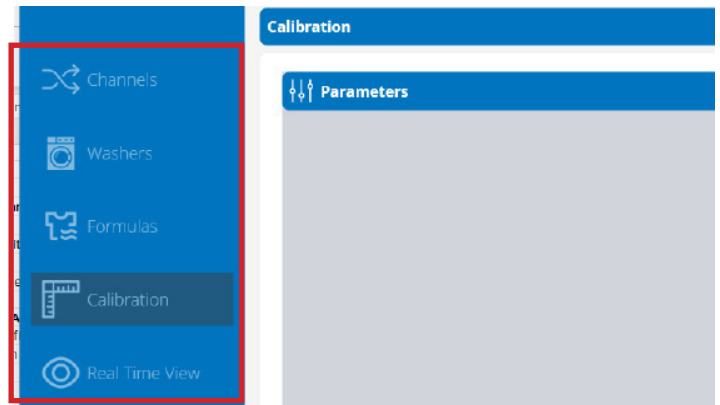

# REAL TIME VIEW

**BRIGHTWELL** Manager

Real Time View

Number	KG	Formula Num.	Formula Name	Washer Customer	Phase Status	Finish	Pause
1	50.00	1	Bedsheets	0	<input checked="" type="checkbox"/> <input checked="" type="checkbox"/> <input type="checkbox"/> <input type="checkbox"/> <input type="checkbox"/> <input type="checkbox"/> <input type="checkbox"/> <input type="checkbox"/> <input type="checkbox"/>	<input type="checkbox"/>	<input type="checkbox"/>
2	0.00	0		0	<input type="checkbox"/> <input type="checkbox"/> <input type="checkbox"/> <input type="checkbox"/> <input type="checkbox"/> <input type="checkbox"/> <input type="checkbox"/> <input type="checkbox"/> <input type="checkbox"/>	<input type="checkbox"/>	<input type="checkbox"/>

- 1 Number 1 is the machine real-time dashboard
- 2 Number 2 opens the more in depth machine information screen

# REAL TIME VIEW

## STEP 1

If you expand the view on a single machine you can view more in depth details about the status. The main screen will show:

- Formula Number
- Formula Name
- KG
- Phase
- Customer

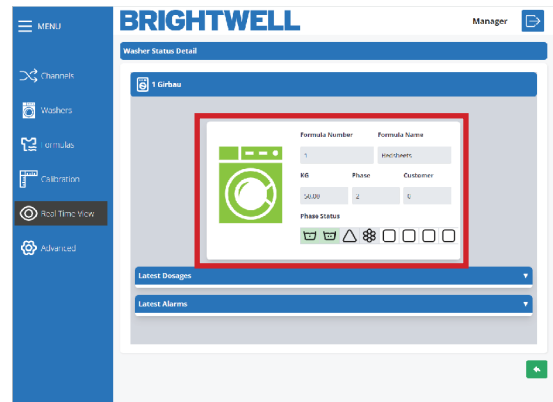

## STEP 2

If you choose to expand the Latest Dosages tab it will display more detailed information along with time stamps.

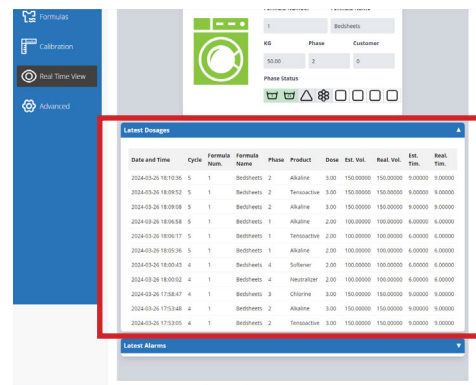

## STEP 3

You also have the ability to expand all the alarm information on the Brightwell page. Displaying any issues that the machine has encountered in the latest session.

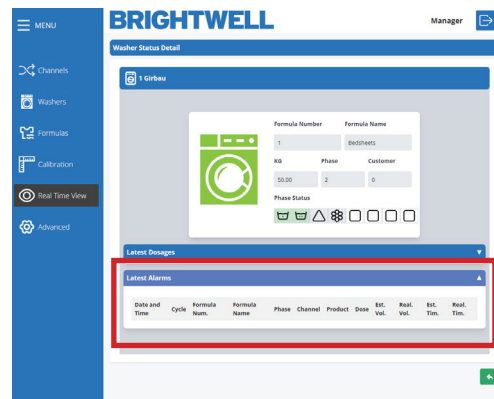

# ADVANCED SETTINGS

**BRIGHTWELL** Manager

Advanced

**Connections**

Network ID Password

MiRedWiFi Password

**Parameters**

Metric Units Language

Metric Not used

Save

- 1** Number 1 allows you to edit the current Wifi settings. Using the drop down menu to change the Network ID and the textbox to adjust the password.
- 2** Number 2 are the Units and language settings for the unit. Allowing you to adjust based on your needs.
- 3** Number 3 is the Save icon. Use this to save any settings you have adjusted from the menu above.

# UPLOADING JSON FILES FOR THE FIRST TIME

## STEP 1

To upload JSON files to your unit via the configuration tool for the first time you need to download ALL JSON files from the Portal. Please refer to the **Data Transfer Saving a JSON file**.

To access the data transfer menu press the **Upload File** button.

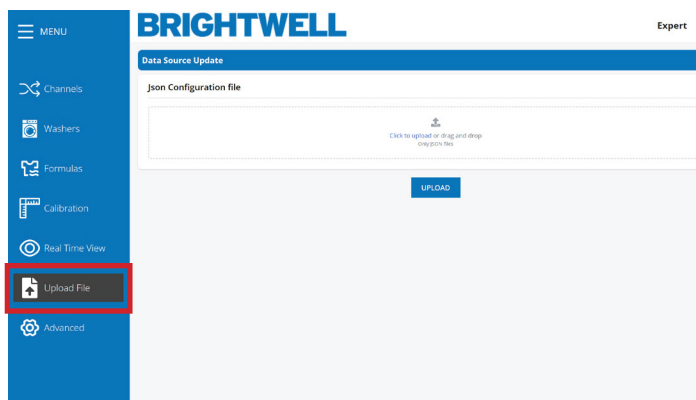

## STEP 2

You will need to upload the files in the following order:

- User
- Site
- Channel
- Products
- Washers
- Formulas

Take your JSON file \* and drop it onto the upload box, or alternatively press the **Click to Upload** and select it from your machine.

\* (These files are generated via the Portal. Please see the section - **Data Transfer Saving a JSON file** in the Portal manual)

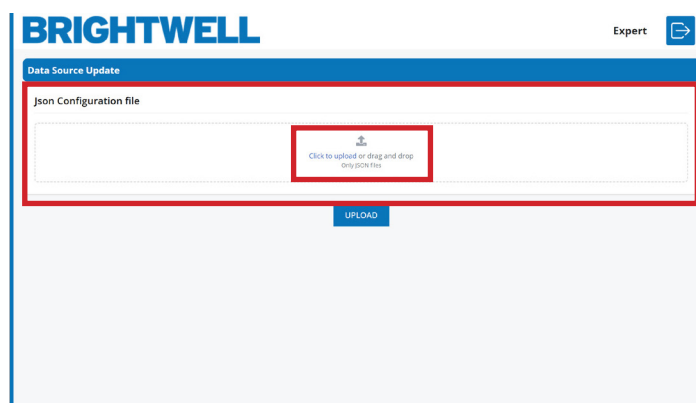

## STEP 3

Press the Upload button to upload this to your unit.

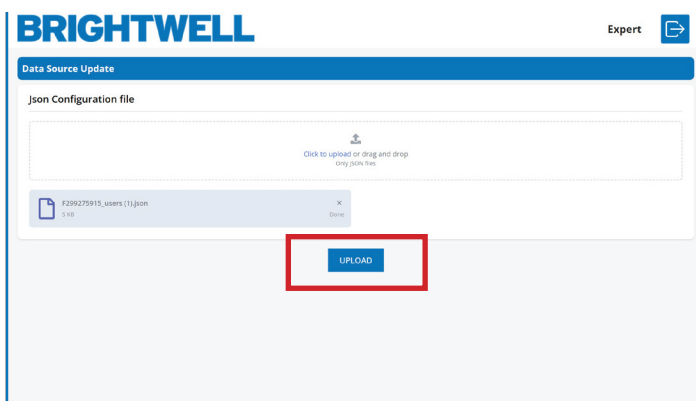

## STEP 4

If this has been successful you will receive the following confirmation message.

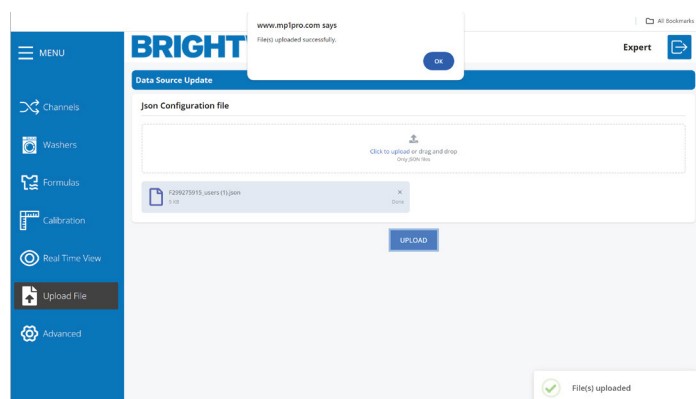

# MAKING CHANGES WITH A SINGLE JSON FILE

## STEP 1

To access the data transfer menu press the **Upload File** button.

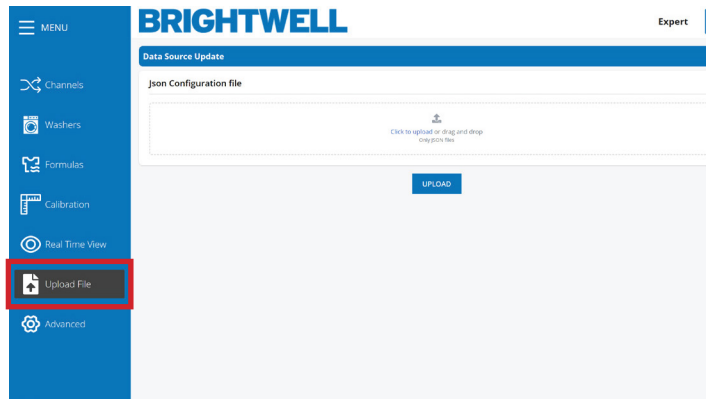

## STEP 2

Take your individual JSON file \* and drop it onto the upload box, or alternatively press the Click to Upload and select it from your machine

\* (This is generated via the Portal. Please see the section - Data Transfer Saving a JSON file in the Portal manual)

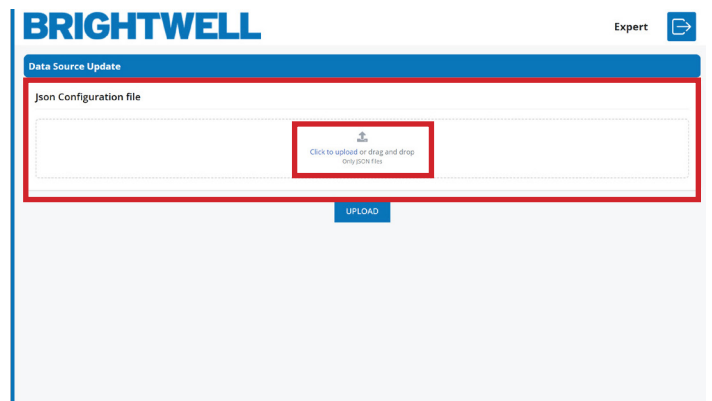

## STEP 3

Press the Upload button to upload this to your unit.

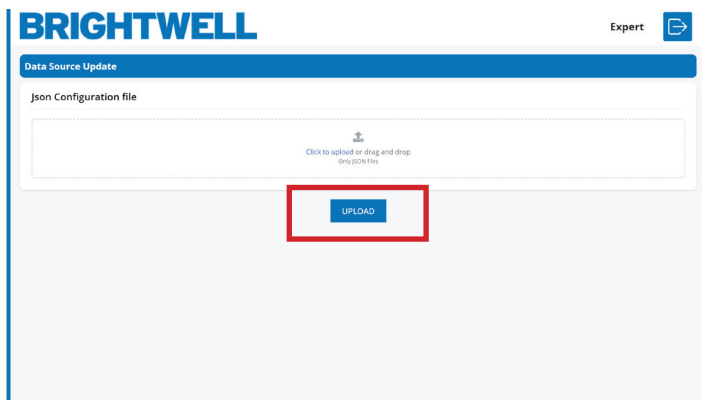

## STEP 4

If this has been successful you will receive the following confirmation message.

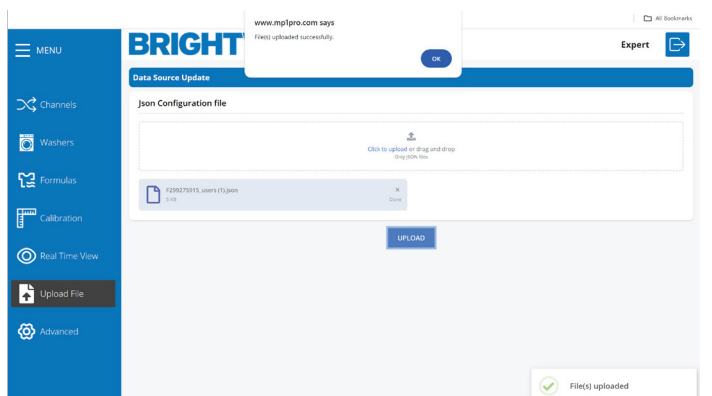

# BRIGHTWELL